

Optocoupler with Phototriac Output

Description

The K3010P(G) Series consist of a phototransistor optically coupled to a gallium arsenide infrared emitting diode in a 6 lead plastic dual inline packages.

The elements are mounted on one leadframe in coplanar technique, providing a fixed distance between input and output for highest safety requirements.

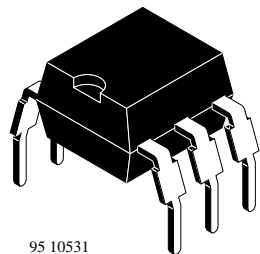

95 10531

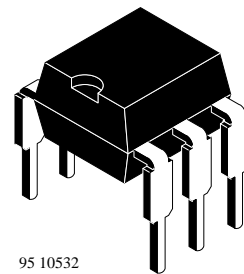

95 10532

Applications

Circuits for safe protective separation against electrical shock according to safety class II. (reinforced isolation):

- for application class I – IV at main voltage ≤ 300 V;
- for application class I – III at main voltage ≤ 600 V according to VDE 0884, table 2, suitable for:

Monitors, air conditioners, line switches, solid state relays, microwaves.

These couplers perform safety functions according to following equipment standards:

- **VDE 0884**
Optocoupler providing protective separation
- **VDE 0804**
Telecommunication apparatus and data processing
- **VDE 0805/IEC 950/EN 60950**
Office machines (applied for reinforced isolation for main voltages ≤ 400 V_{RMS})
- **VDE 0860/IEC 64**
Safety for mains operated electronic and related apparatus for household



0884

Pin Connection

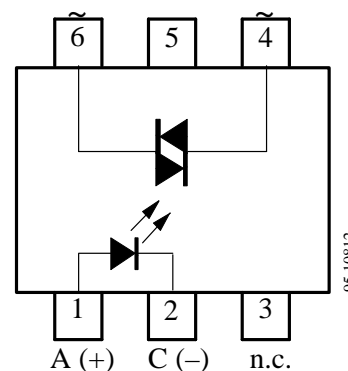

Note: Pin 5 must not be connected

K3010P(G) Series

Features

According to VDE 0884

- Rated impulse voltage (transient overvoltage)
 $V_{IOTM} = 6 \text{ kV peak}$
- Isolation test voltage (partial discharge test voltage)
 $V_{pd} = 1.6 \text{ kV}$
- Rated isolation voltage (RMS includes DC)
 $V_{IOWM} = 600 \text{ V}_{RMS} (848 \text{ V peak})$
- Rated recurring peak voltage (repetitive)
 $V_{IORM} = 600 \text{ V}_{RMS}$
- Isolation materials according to UL 94-VO
- Thickness through insulation $\geq 0.75 \text{ mm}$
- Further approvals:
BS EN 60065 (BS 415), BS EN 60950 (BS 7002),
BS EN 41003, UL 1577, File No. E 76222
- Creeping current resistance according to
VDE 0303/IEC 112
Comparative Tracking Index: **CTI = 275**
- Pollution degree 2 (DIN/VDE 0110 resp. IEC 664)
- Climatic classification
55/100/21 (IEC 68 part 1)
- Special construction:
therefore extra low coupling capacity typical 0.2 pF,
high **Common Mode Rejection**
- I_{FT} offered in 3 groups

Absolute Maximum Ratings

Input (Emitter)

Parameters	Test Conditions	Type	Symbol	Value	Unit
Reverse voltage			V_R	5	V
Forward current			I_F	80	mA
Forward surge current	$t_p \leq 10 \mu\text{s}$		I_{FSM}	3	A
Power dissipation	$T_{amb} \leq 25^\circ\text{C}$		P_v	100	mW
Junction temperature			T_j	100	$^\circ\text{C}$

Output (Detector)

Parameters	Test Conditions	Type	Symbol	Value	Unit
Off state output terminal voltage		K3010P(G) K3011P(G) K3012P(G)	V_{DRM}	250	V
On state RMS current			I_{TRMS}	100	mA
Peak surge current, non-repetitive	$t_p \leq 10 \text{ ms}$		I_{TMS}	1.5	A
Power dissipation	$T_{amb} \leq 25^\circ\text{C}$		P_v	300	mW
Junction temperature			T_j	100	$^\circ\text{C}$

Coupler

Parameters	Test Conditions	Type	Symbol	Value	Unit
Isolation test voltage (RMS)			$V_{IO}^{1)}$	3.75	kV
Total power dissipation	$T_{amb} \leq 25^\circ\text{C}$		P_{tot}	350	mW
Ambient temperature range			T_{amb}	-40 to +85	$^\circ\text{C}$
Storage temperature range			T_{stg}	-55 to +100	$^\circ\text{C}$
Soldering temperature	2 mm from case, $t \leq 10 \text{ s}$		T_{sd}	260	$^\circ\text{C}$

¹⁾ related to standard climate 23/50 DIN 50014

Maximum Safety Ratings ²⁾ (according to VDE 0884)

Input (Emitter)

Parameters	Test Conditions	Symbol	Value	Unit
Forward current		I_{si}	130	mA

Output (Detector)

Parameters	Test Conditions	Symbol	Value	Unit
Power dissipation	$T_{amb} \leq 25^{\circ}\text{C}$	P_{si}	600	mW

Coupler

Parameters	Test Conditions	Symbol	Value	Unit
Rated impulse voltage		V_{IOTM}	6	kV
Safety temperature		T_{si}	150	$^{\circ}\text{C}$

- ²⁾ This device is used for protective separation against electrical shock only within the maximum safety ratings. This must be ensured by protective circuits in the applications.

Derating Diagram

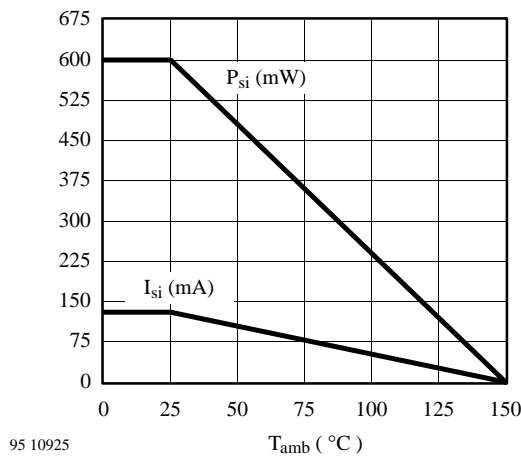

K3010P(G) Series

Electrical Characteristics

$T_{amb} = 25^{\circ}\text{C}$

Input (Emitter)

Parameters	Test Conditions	Type	Symbol	Min.	Typ.	Max.	Unit
Forward voltage	$I_F = 50\text{ mA}$		V_F		1.25	1.6	V
Breakdown voltage	$I_R = 100\text{ }\mu\text{A}$		$V_{(BR)}$	5			V
Junction capacitance	$V_R = 0,$ $f = 1\text{ MHz}$		C_j		50		pF

Output (Detector)

Parameters	Test Conditions	Type	Symbol	Min.	Typ.	Max.	Unit
Forward peak off-state voltage (repetitive)	$I_{DRM} = 100\text{ nA}$	K3010P(G) K3011P(G) K3012P(G)	$V_{DRM}^{3)}$	250			V
Peak on state voltage	$I_{TM} = 100\text{ mA}$		V_{TM}		1.5	3	V
Critical rate of rise of off state voltage, (see test circuit)	$I_{FT} = 0$ $I_{FT} = 30\text{ mA}$		$(dv/dt)_{cr}$ $(dv/dt)_{crq}$	0.1	10 0.2		V/ μs V/ μs

Coupler

Parameters	Test Conditions	Type	Symbol	Min.	Typ.	Max.	Unit
AC Isolation test voltage (RMS)	$f = 50\text{ Hz}, t = 1\text{ s}$		$V_{IO}^{4)}$	3.75			kV
Emitting diode trigger current	$V_S = 3\text{ V},$ $R_L = 150\text{ }\Omega$	K3010P(G) K3011P(G) K3012P(G)	I_{FT}		8 5 2	15 10 5	mA mA mA
Holding current	$I_F = 10\text{ mA},$ $V_S \geq 3\text{ V}$		I_H		100		μA

3) Test voltage must be applied within dv/dt ratings

4) related to standard climate 23/50 DIN 50014

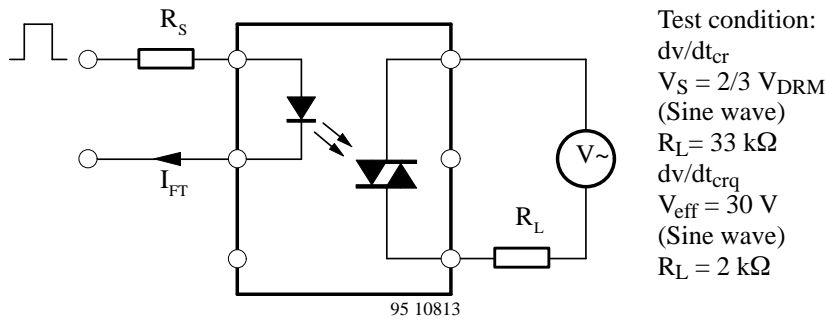
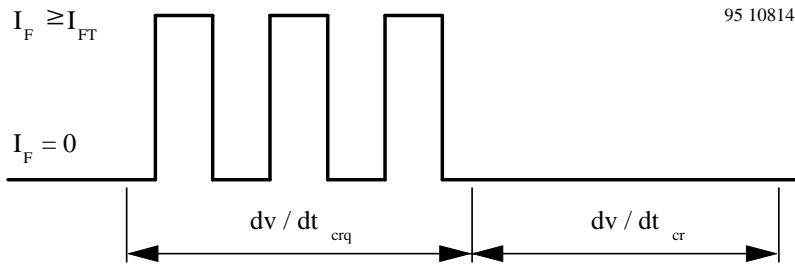

Figure 1. Test circuit for dv/dt_{cr} and dv/dt_{crq}



- dv/dt_{cr} Highest value of the “rate of rise of off-state voltage” which will cause no switching from the off-state on the on-state
- dv/dt_{crq} Highest value of the “rate of rise of commutating voltage” which will not switch on the device again, after the voltage has decreased to zero and the trigger current is switched from I_{FT} to zero

Figure 2.

Application

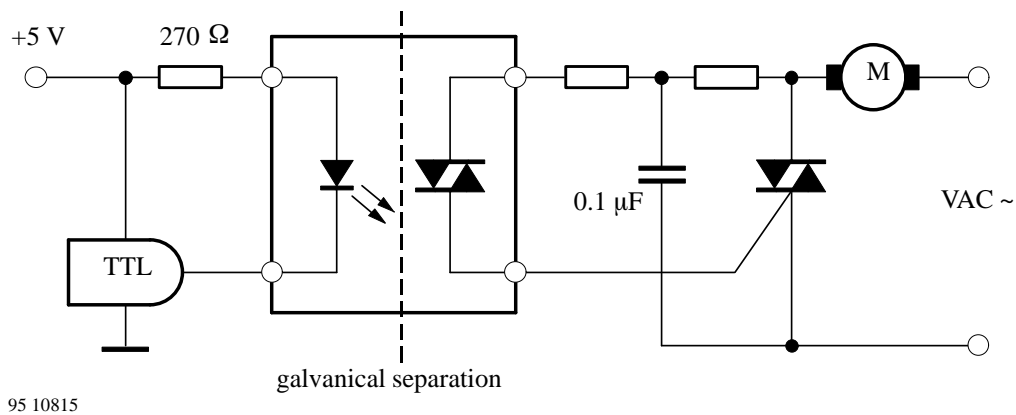

Figure 3. Motor control circuit

Insulation Rated Parameters (according to VDE 0884)

Parameters		Test Conditions	Symbol	Min.	Typ.	Max.	Unit
Partial discharge test voltage	Routine test	100%, $t_{\text{test}} = 1 \text{ s}$	V_{pd}	1.6			kV
	Lot test (sample test)	$t_{\text{Tr}} = 10 \text{ s}$, $t_{\text{test}} = 60 \text{ s}$	V_{IOTM}	6			kV
		see figure 4	V_{pd}	1.6			kV
Insulation resistance		$V_{\text{IO}} = 500 \text{ V}$	R_{IO}	10^{12}			Ω
		$V_{\text{IO}} = 500 \text{ V}$, $T_{\text{amb}} = 100^\circ\text{C}$	R_{IO}	10^{11}			Ω
		$V_{\text{IO}} = 500 \text{ V}$, $T_{\text{amb}} = 150^\circ\text{C}$ (only construction test)	R_{IO}	10^9			Ω

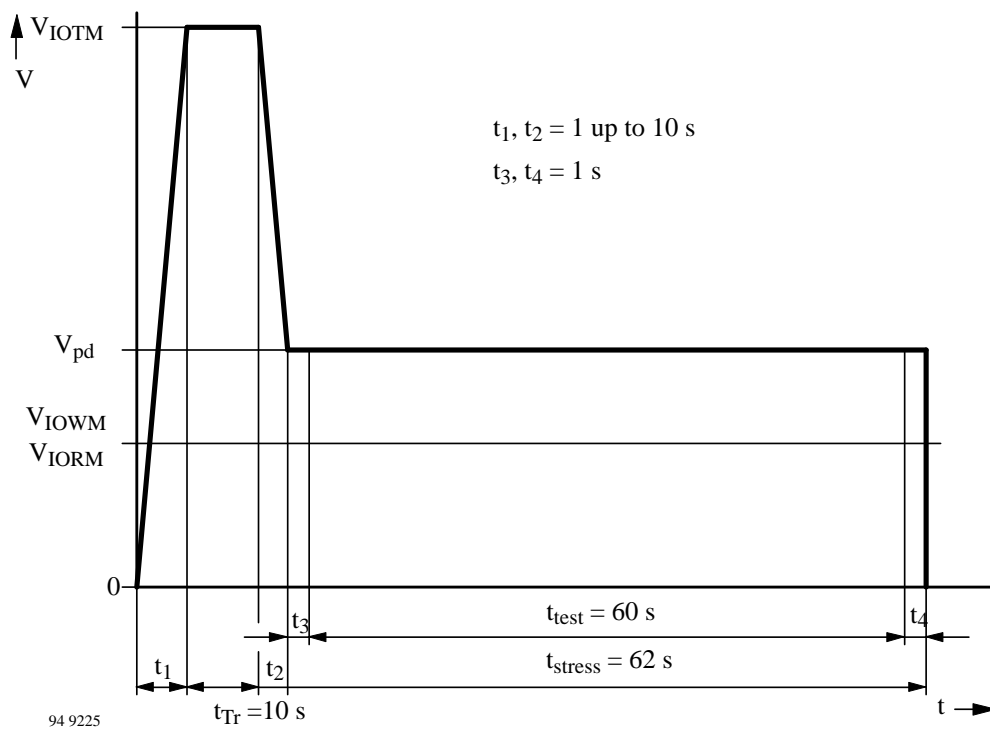
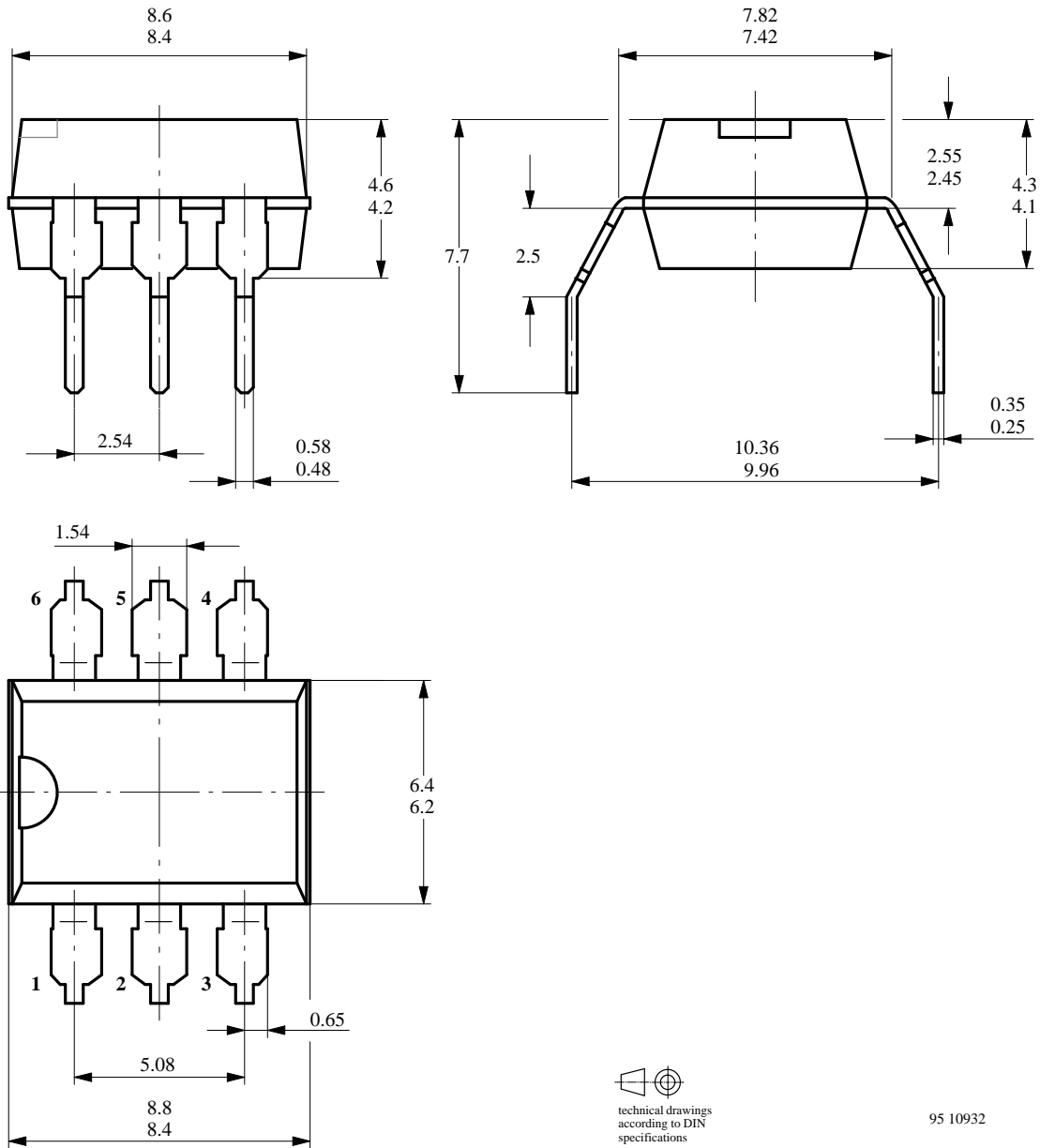

Figure 4. Test pulse for sample test according to DIN VDE 0884

Dimensions in mm

Leadform 10.16. mm (G-type)





technical drawings
according to DIN
specifications

95 10932

K3010P(G) Series

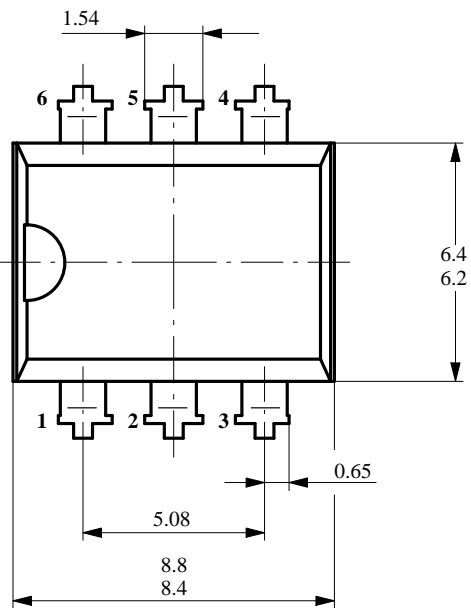
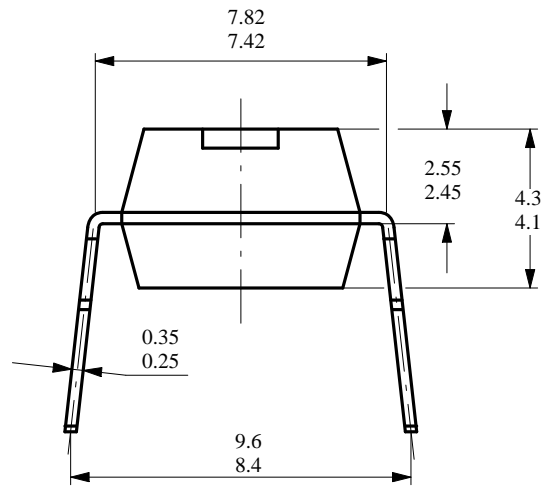
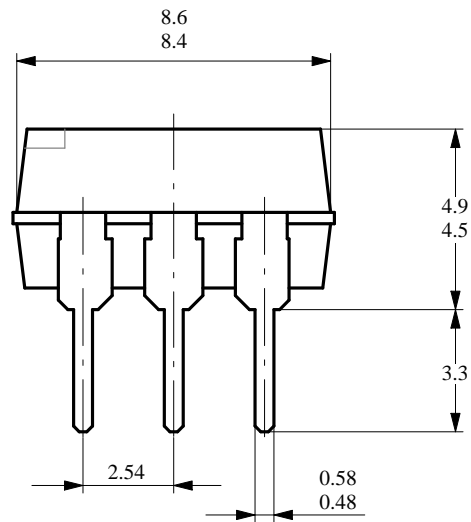
Dimensions in mm



technical drawings
according to DIN
specifications

95 10931

Ozone Depleting Substances Policy Statement

It is the policy of **TEMIC TELEFUNKEN microelectronic GmbH** to

1. Meet all present and future national and international statutory requirements.
2. Regularly and continuously improve the performance of our products, processes, distribution and operating systems with respect to their impact on the health and safety of our employees and the public, as well as their impact on the environment.

It is particular concern to control or eliminate releases of those substances into the atmosphere which are known as ozone depleting substances (ODSs).

The Montreal Protocol (1987) and its London Amendments (1990) intend to severely restrict the use of ODSs and forbid their use within the next ten years. Various national and international initiatives are pressing for an earlier ban on these substances.

TEMIC TELEFUNKEN microelectronic GmbH semiconductor division has been able to use its policy of continuous improvements to eliminate the use of ODSs listed in the following documents.

1. Annex A, B and list of transitional substances of the Montreal Protocol and the London Amendments respectively
2. Class I and II ozone depleting substances in the Clean Air Act Amendments of 1990 by the Environmental Protection Agency (EPA) in the USA
3. Council Decision 88/540/EEC and 91/690/EEC Annex A, B and C (transitional substances) respectively.

TEMIC can certify that our semiconductors are not manufactured with ozone depleting substances and do not contain such substances.

We reserve the right to make changes to improve technical design and may do so without further notice.

Parameters can vary in different applications. All operating parameters must be validated for each customer application by the customer. Should the buyer use TEMIC products for any unintended or unauthorized application, the buyer shall indemnify TEMIC against all claims, costs, damages, and expenses, arising out of, directly or indirectly, any claim of personal damage, injury or death associated with such unintended or unauthorized use.

TEMIC TELEFUNKEN microelectronic GmbH, P.O.B. 3535, D-74025 Heilbronn, Germany
Telephone: 49 (0)7131 67 2831, Fax number: 49 (0)7131 67 2423